



ÖSTERREICHISCHER AERO-CLUB

SEKTION FAA Blattgasse 6, A-1030 WIEN

Sicherheitsmitteilung SM040401

Datum: 12.07.04

Hersteller: Parachutes de France,
2 rue Denis Papin,
Juoy le Moutier
95031 Cergy Pontoise Cedex,
France

Herstellerbulletin: N°04/001

Betrifft: Freebag

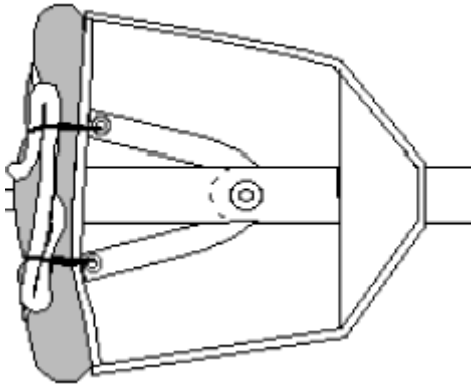

Betroffene Systeme: Freebags mit den Batchnummern 32554 bis 8003676

Problem: Verkleben der beschichteten Innenseite des Freebags mit dem Material der Reservekappe.

Maßnahmen: Überprüfen, ob das Freebag eine betroffene Batchnummer hat. Die Batchnummer befindet sich auf der Klappe unter der die Fangleinen der Reserve verstaut werden. Sollte das der Fall sein, und es wurde eine Verklebung zwischen Freebag und Kappe festgestellt, so muss das Freebag an Parachutes de France geschickt werden

Status: Verpflichtend

Wirksamkeitsdatum: Beim nächsten Reservepacken

Beilagen: Herstellerbulletin N° 04/001

PARACHUTES DE FRANCE

2 rue Denis Papin
Jouy le Moutier
95031 Cergy Pontoise Cedex
France

Tel. 33 (0)1 34 32 77 77
Fax 33 (0)1 34 32 73 17

Safety Bulletin

Addressees: All reserve canopy packers and users

N°04/001

Date:
19/04/04

Page 1/1

Affected Equipment :

All the FREEBAGS with the batch numbers ranging from 32554 to 8003676 (this number is indicated on flap covering the lines).

Observations :

The inside surface of the FREEBAG may adhere to the canopy.

Analysis :

The fabric of the FREEBAG has a coating on the inside that may sometimes cause a superficial adherence.

Recommendations for use :

The adherence level that has been observed has no impact on the airworthiness of the equipments. Therefore those equipments will keep on being used as they are until the reserve canopy is re-packed.

Action :

As the FREEBAG is an interchangeable part, an inspection of **all the Parachutes de France equipments** that are in use will have to be carried out during the next packing of the reserve canopy(*).

Procedure to follow during the inspection :

- Take down the "BATCH" number in order to determine if it is included in the above-mentioned range (ie from 32554 to 8003676),
- If it is the case, check if there is any kind of adherence between the reserve FREEBAG and the reserve canopy,
- If it is the case, send back the FREEBAG to Parachutes De France (see above-mentioned address). It will be replaced after our technical department has checked it.

(*)The batch numbers of the FREEBAGS made of thin fabric (manufactured before 1999) and those of the non-coated FREEBAGS (manufactured after 2001) are not included in the above-mentioned range. They are not affected by this problem.